

2018-19

HANDBOOK OF INFORMATION



UNDERGRADUATE
PROGRAMME

HANDBOOK OF INFORMATION

UNDERGRADUATE PROGRAMME

2018-19



INDIAN INSTITUTE OF TECHNOLOGY ROPAR

Rupnagar, Punjab-140001 (INDIA)

www.iitrpr.ac.in

CONTENTS

1 Introduction	1
1.1 Background	1
1.2 Departments and Centres	1
1.3 Programmes Offered	1
1.3.1 Undergraduate Programmes	1
1.4 Student's Entry Number	2
2 Academic System	3
2.1 Academic Programmes	3
2.2 Credit System	3
2.2.1 Course Credits Assignment	3
2.2.2 Earning credits	3
2.2.3 Course Coordinator	4
2.2.4 Grading System	4
2.2.5 Description of Grades	5
2.2.6 Evaluation of Performance	6
2.2.7 Course Numbering Scheme	8
2.3 Registration and Attendance	8
2.3.1 Registration	8
2.3.2 Registration and Student Status	8
2.3.3 Advice on Courses	8
2.3.4 Registration Validation	8
2.3.5 Late Registration	8
2.3.6 Add, Drop, Audit and Withdrawal from Courses	9
2.3.7 Semester Withdrawal	9
2.3.8 Registration and Fees Payment	9
2.3.9 Registration Record	9
2.3.10 Continuous Absence and Registration Status	9
2.3.11 Attendance Rules	9
2.4 Rules and Regulations	10
2.4.1 Absence during the Semester	10
2.4.2 Branch Change at the end of First Year	10
2.4.3 Measures for Helping SC/ST Students	10
2.5 Curriculum and Structure of the Bachelor of Technology Programmes	11
2.5.1 Programme and Credit Structure	11
2.5.2 Credit structure of the basic B. Tech. programme	11
2.5.3 Overall credit structure for all the four options	12
2.5.4 Credit Limits	12
2.5.5. CGPA Requirement for Minor, Concentration, Honors, or "6-Month Internship" ..	12
2.5.6. Minimum CGPAfor award of B. Tech. Degree	12
2.5.7 Special Requirements	12
2.6 Performance Requirements and Monitoring	13
2.6.1 Maximum Period for Completing Degree Requirements	13
2.6.2 Conditions for Termination of Registration, Probation and Warning	13
2.6.3 Slow-paced Programme	13
2.7 Selection of courses for the Basic B.Tech. in Civil Engineering/ Chemical Engineering /Computer Science & Engineering/ Electrical Engineering/Mechanical Engineering/Metallurgical & Materials Engineering	14

2.8 Sequence of the courses for all the B.Tech. Programme	16
2.8.1 Course Plan for B.Tech. with Minor	19
2.8.2 Course Plan for B.Tech. with Concentration	19
2.8.3 Course Plan for B.Tech. (Honors)	19
2.8.4 Course Plan for Basic B.Tech. with Additional Internship	19
2.8.5 Comparing Different Options	20
2.9 B.Tech. - M.Tech. Dual Degree in Mechanical Engineering	22
2.10 Sequence of Courses	22
3 Fees	26
3.1 Mode of Payment	26
3.2 Deadlines for Payment	26
3.3 Refund of Fees	26
3.4 Withdrawal from the Institute	26
3.5 Transcripts, Degree and other Certificates	27
3.6 Details of Semester Fees for the Academic Year 2018-19	28
4 Discipline and Attendance	29
4.1 Discipline	29
4.2 Punishment to the students who indulge in unfair means during quizzes/ mid semester/end-semester examinations	29
5 Honour Code	30
6 Academic Integrity	31
7 Scholarships and Fellowships	33
7.1 Scholarship for B.Tech. Students	33
7.1.1 Institute Merit-cum-Means (MCM) Scholarships	33
7.1.2 Institute Merit Prizes and Certificates	33
7.1.3 Institute Free Studentship	34
7.1.4 Scholarship provision for Students of SC/ST Category	35
7.1.5 Post-Matric Scholarship	34
7.2 Top Class Education Scholarship for SC/ST students	34
7.3 Other Scholarship	34
7.4 Scholarship for B.Tech. - M.Tech. dual degree	35
8 Library Facilities	35
9 Health Care	35
10 Hostels and Dining Facilities	35
11 Student Activities	36
12 Recreational Facilities	36
13 General Facilities	36
14 Details of Medals	36
15 Academic Calendar for 1st Semester 2018-19	36

1 Introduction

1.1 Background

The Indian Institute of Technology Ropar is one of the eight IITs set up by the Ministry of Human Resource Development (MHRD), Government of India in 2008. In keeping with the spirit of the IIT system, this institute is committed to provide state-of-the-art technical education in a variety of fields, and also to facilitate transmission of knowledge using the latest developments in pedagogy. In its initial years, IIT Ropar was mentored by IIT Delhi, and the first academic session (2008) of IIT Ropar was held at the campus of IIT Delhi. The institute started operating from the transit campus, i.e., the premises of the Government Polytechnic College for Girls (Ropar) from 18 August 2009. The transit campus of IIT Ropar has all the required facilities such as class rooms fitted with multimedia, faculty rooms and an administrative wing. The four hostels (three for boys and one for girls) on campus have modern mess halls. Faculty recruitment, creation of laboratories and other support facilities are in full swing. The main campus is spread over an area of 500 acres, and is situated on the banks of the Satluj river. The Institute has started functioning from its main campus.

1.2 Departments and Center

Each course is offered by an academic unit which could either be a department or center. Departments and their two letter codes are given below. Some courses are offered jointly by multiple academic units and are classified as interdisciplinary courses.

Academic Departments and Centre

Sr. No.	Name of Academic Unit (alphabetical order)	Code
1	Center for Biomedical Engineering	BM
2	Chemical Engineering	CH
3	Chemistry	CY
4	Civil Engineering	CE
5	Computer Science and Engineering	CS
6	Electrical Engineering	EE
7	Humanities and Social Sciences	HS
8	Mathematics	MA
9	Mechanical Engineering	ME
10	Metallurgical & Materials Engineering	MM
11	Physics	PH

1.3 Programmes Offered

IIT Ropar offers a variety of academic programmes for students with a wide range of backgrounds. Admission to many of these programmes are based on the students' performance in national level tests JEE Advanced. For undergraduate programmes, students are admitted after 10+2 schooling. The admission is done through JEE only. For further detail on admission to IIT Ropar, visit www.jeemain.nic.in. The programmes and their specializations are listed below.

1.3.1 Undergraduate Programmes

Bachelor of Technology (B.Tech.)

Sr. No.	Department	Specialization	Code
1	Chemical Engineering	B.Tech. in Chemical Engineering	CH
2	Civil Engineering	B.Tech. in Civil Engineering	CE
3	Computer Science and Engineering	B.Tech. in Computer Science and Engineering	CS
4	Electrical Engineering	B.Tech. in Electrical Engineering	EE
5	Mechanical Engineering	B.Tech. in Mechanical Engineering	ME
6	Metallurgical & Materials Engineering	B.Tech. in Metallurgical & Materials Engineering	MM

Dual Degree Programme

Sr. No.	Department	Specialization	Code
7	Mechanical Engineering	B.Tech.-M.Tech.	MED

1.4 Student's Entry Number

The entry number of a student consists of eleven alpha-numerals.

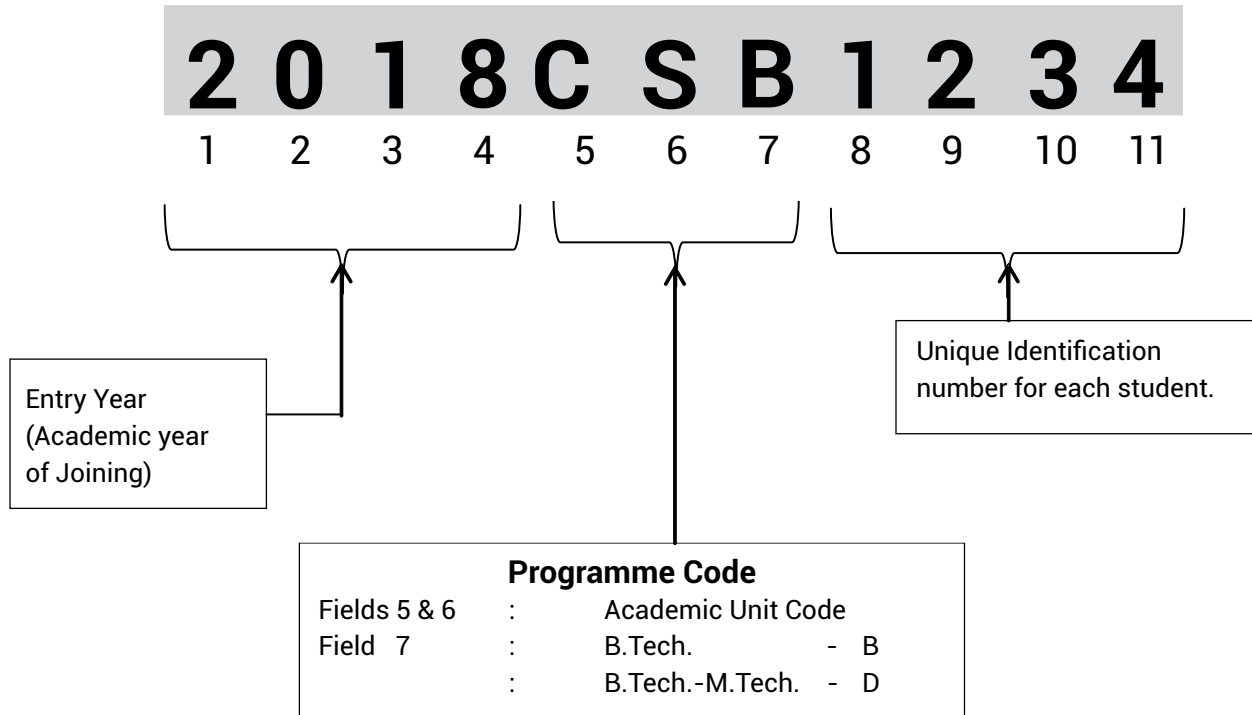

In case of a branch change, the three alphabets (fields 5, 6 and 7) will be changed. However, his / her unique numeric code will remain unchanged. Such students will have two entry numbers, one prior to branch change and one after the change. At any time, though, only one entry number that corresponds to the student's present status will be in use.

2 Academic System

The overall academic system of IIT Ropar has been designed to provide a science-based engineering education with a view to producing quality engineer-scientists. The curriculum provides broad-based knowledge and simultaneously builds a temper for life-long learning and exploring. The undergraduate programme begins with a set of science and general engineering courses which are reflected in the course plan for the first year. These courses provide a foundation for further discipline-specific courses.

The medium of instruction at IIT Ropar is English.

The current Academic year begins in August and ends in May of the following year. For the academic year 2018-19, the 1st semester starts on 7th August 2018. The detailed schedule of the activities and academic deadlines shall be given in the semester schedule that will be available before the start of the semester.

2.1 Academic Programmes

Currently, the following UG programmes are being offered:

- i. Bachelor of Technology in Chemical Engineering
- ii. Bachelor of Technology in Civil Engineering
- iii. Bachelor of Technology in Computer Science and Engineering
- iv. Bachelor of Technology in Electrical Engineering
- v. Bachelor of Technology in Mechanical Engineering
- vi. Bachelor of Technology in Metallurgical & Materials Engineering
- vii. B.Tech. - M.Tech. Dual Degree in Mechanical Engineering

Admission to these programmes, is through the JEE and the students are admitted after completing 10+2 schooling.

2.2 Credit System

Education at the Institute is organized around the semester-based credit system of study. The prominent feature of credit system are a process of continuous evaluation of a student's performance/progress and the flexibility to allow a student to progress at an optimum pace suited to his/her ability or convenience. This feature is subject to the fulfillment of the minimum requirement for continuation.

A student's performance/progress is measured by the number of credits that he/she has earned, i.e., completed with a pass grade. Based on the course credits and grade obtained by the student, the grade point average is calculated. A minimum grade point average is required to be maintained for satisfactory progress and continuation in the programme.

Each programme has a maximum credit requirement and a pattern of credit distribution over courses of different categories. Details are given below.

2.2.1 Course credits assignment

Each course, except a few special courses, has a certain number of credits assigned to it depending upon its lecture, tutorial, practical and total preparation hours by the students (L-T-P-S-C) in a week. This weighting also indicates the academic expectation that includes in-class contact and self-study beyond class hours. A few courses are without credit and are referred to as non-credit (NC) courses.

L = No. of lecture 'hours' (actually 50 min.) per week, T = No. of tutorial 'hours' = L/3, by default.

P = No. of laboratory 'hours'.

S = Total preparation 'hours' by students including assignments and self-study, $S=2L+P/2-T$.

C = Total credit-terms, $C=L+P/2$.

2.2.2 Earning credits

At the end of every course, a letter grade is awarded in each course for which a student had registered. On obtaining a pass grade, the student accumulates the course credits as earned credits. A student's performance is measured by the number of credits that he/she has earned and by the weighted grade point average.

2.2.3 Course Coordinator

Every course is usually coordinated by a member of the teaching staff of the department which is offering the course in a given semester. This faculty member is designated as the Course Coordinator. He/she has the full responsibility of conducting the course, coordinating the work of the other members of the faculty as well as teaching assistants involved in that course, holding the tests and assignments, and awarding the grades. For any difficulty related to a course, the student is expected to approach the respective course coordinator for advice and clarification. The distribution of the weight for tests, quizzes, assignments, laboratory work, workshop and drawing assignment, term paper, etc. that will be the basis for award of the grade in a course will be decided by the course coordinator of that course and generally announced at the start of the semester.

2.2.4 Grading System

The grading reflects a student's own proficiency in the course. While the relative standing of the student is clearly indicated by his/her grades, the process of awarding grades is not necessarily based upon some statistical distribution of performance of the whole class. The course coordinator and the associated faculty for a course formulate appropriate procedures to award grades that are reflective of the student's performance vis-a-vis the instructor's expectation.

The credit system enables continuous evaluation of a student's performance, and allows the student to progress at an optimum pace suited to individual ability and convenience. This is subject to the fulfilling of the minimum requirements for continuation.

The grades and their description, along with equivalent numerical points wherever applicable are listed below:

Grades with their description

Grade	Grade Points	Description
A	10	Outstanding
A (-)	9	Excellent
B	8	Very good
B (-)	7	Good
C	6	Average
C (-)	5	Below average
D	4	Marginal
E	2	Poor
F	0	Very poor
NP	-	Audit Pass
NF	-	Audit Fail
I	-	Incomplete
W	-	Withdrawal

2.2.5 Description of Grades

A grade

The 'A' grade stands for outstanding achievement. The minimum percentage for the award of an 'A' grade is 80%. However, individual course coordinators may set a higher performance requirement.

B grade

The 'B' grade refers to very good/good performance.

C grade

The 'C' grade stands for average performance. This average performance refers to "average" as per instructor's expectations in a holistic sense and not on the average marks.

D grade

The 'D' grade stands for marginal performance, i.e., it is the minimum pass grade in any course. The minimum percentage for the award of 'D' grade is 30%, however, individual course coordinators may set a higher marks requirement.

E and F grades

The 'E' and 'F' grades denote poor and very poor performance, and indicate failing a course. An 'F' grade is also awarded in case of poor attendance (see Attendance Rules). A student has to repeat all the core courses in which he/she obtains either an 'E' or an 'F' grade, until a pass grade is obtained. In case of the elective courses in which either an 'E' or an 'F' grade has been obtained the student may take the same course or any other course from the same category. An 'E' grade in a course makes a student eligible to repeat the course in the summer semester, if the course is offered. Further, 'E' and 'F' grades secured in any course stay permanently on the grade card. These grades are not counted in the calculation of the CGPA; however, these are counted in the calculation of the SGPA.

NP and NF grades

The 'NP' Grade denotes completion of the Audit course. The NF grade denotes Audit fail. These grades are awarded in a course that the student opts to audit. Only an elective course can be audited until one week after the mid semester examination. The Audit Pass (NP) is awarded if the student's attendance is above 75% in the class and he/she has obtained at least a 'D' grade. The Course Coordinator can specify a higher criterion for audit pass at the beginning of the semester. If either of these requirements is not fulfilled, an audit fail (NF) is awarded. The grades obtained in an audit course are not considered for the calculation of SGPA or CGPA.

I grade

The 'I' grade denotes incomplete performance in any L (lecture), P (practical), V (special module) category courses. It may be awarded in case of absence on medical grounds or other special circumstances, before or during the major examination period. The student should complete all requirements within:

- (i) 10 days of the last date of the Major Tests; the request is to be made to the Head of the Department of the student's programme who will notify the same to the concerned course coordinators, OR
- (ii) With the permission of the Dean (Academics) the period can be extended to the first week of the next semester. Upon completion of all course requirements, the 'I' grade is converted to a regular grade (A to F, NP or NF). The 'I' grade does not appear permanently in the grade card. Requests for an I-grade should be made at the earliest but not later than the last day of the major tests.

For (ii), the request is to be made to the Dean (Academics). A student may be considered for the award of an 'I' grade in a course only if the attendance in the course is 75%.

Attendance in the course for which an I-grade is being sought will be certified by the course coordinator of the course.

W grade

The 'W' grade is awarded in a course where the student has opted to withdraw from the course. Withdrawal from a course is permitted until one week after the Mid Semester Examination. The W grade stays on the grade card.

2.2.6 Evaluation of Performance

The performance of a student will be evaluated in terms of two indices, viz. the Semester Grade Point Average (SGPA) which is the Grade Point Average for a semester, and Cumulative Grade Point Average (CGPA) which is the Grade Point Average for all the completed semesters at any point in time.

The Earned Credits (E.C.) are defined as the sum of course credits of courses in which students have been awarded grades between A to D; for UG students, credits from courses in which an NP grade has been obtained are also added.

Points earned in a course = (Course credits × Grade Point) for courses in which A– F grade has been obtained. The SGPA is calculated on the basis of grades obtained in all courses registered in the particular semester, except the audit courses in which an NP/NF grade has been awarded.

$$\text{SGPA} = \frac{\text{Points secured in the semester}}{\text{Credits registered in the semester, excluding audit grade courses}}$$

The CGPA is calculated on the basis of all pass grades, except the courses in which NP/NF grade has been awarded, obtained in all completed semesters.

$$\text{CGPA} = \frac{\text{Cumulative points secured in all passed courses (A-D)}}{\text{Cumulative earned credits, excluding audit grade courses}}$$

An example of these calculations is given below:

Typical academic performance calculations-I semester

Course no.	Course credits	Grade awarded	Earned credits	Grade Points	Points secured
(column 1)	(column 2)	(column 3)	(column 4)	(column 5)	(column 6)
MAXXX	5	C	5	6	30
CSXXX	4	C(-)	4	5	20
PHXXX	4	A	4	10	40
PHXXX	2	B	2	8	16
MEXXX	4	E	0	2	08
CEXXX	2	NP	2	–	–

Credits registered in the semester (total of column 2)	= 21
Credits registered in the semester excluding audit grade course	= 19
Earned credits in the semester (total of column 4)	= 17
Earned credits in the semester excluding audit grade courses	= 15
Points secured in this semester (total of column 6)	= 114
Points secured in this semester in all passed courses (Total of column 6 & A–D grade)	= 106

$$\text{SGPA} = \frac{\text{Points secured in the semester}}{\text{Credits registered in the semester, excluding audit grade course}} = \frac{114}{19} = 6.000$$

$$\text{CGPA} = \frac{\text{Cumulative points secured in all passed courses (A-D)}}{\text{Cumulative earned credits, excluding audit grade courses}} = \frac{106}{15} = 7.067$$

Semester performance: Earned credits (E.C.)= 17 SGPA = 6.000
 Cumulative Performance: Earned credits (E.C.)= 17 CGPA = 7.067

Typical academic performance calculations-II semester

Course no.	Course credits	Grade awarded	Earned credits	Grade Points	Points secured
(column 1)	(column 2)	(column 3)	(column 4)	(column 5)	(column 6)
MAXXX	5	B	5	8	40
EEXXX	4	A(-)	4	9	36
CYXXX	4	W	—	—	—
CYXXX	2	B(-)	2	7	14
MEXXX	4	C	4	6	24
CHXXX	4	A	4	10	40
HUXXX	1	NP	1	—	—

Credits registered in the semester (total of column 2) = 24
 Credits registered in the semester excluding audit grade courses = 23
 Earned credits in the semester (total of column 4) = 20
 Earned credits in the semester excluding audit grade courses = 19
 Points secured in this semester (total of column 6) = 154
 Points secured in this semester in all passed courses
 (Total of column 6 & A-D grade) = 154
 Cumulative points earned in all
 passed courses = 106 (past semesters) + 154 (this sem.) = 260

$$\text{SGPA} = \frac{\text{Points secured in the semester}}{\text{Credits registered in the semester, excluding audit grade course}} = \frac{154}{19} = 8.105$$

$$\text{CGPA} = \frac{\text{Cumulative points secured in all passed courses (A-D)}}{\text{Cumulative earned credits, excluding audit grade courses}} = \frac{106+154}{15+19} = 7.647$$

Cumulative earned credits = 17 (past semesters) + 20 (this semester) = 37

Semester performance: Earned credits (E.C.)= 20 SGPA = 8.105
 Cumulative Performance: Earned credits (E.C.)= 37 CGPA = 7.647

2.2.7 Course Numbering Scheme

Every course runs for the full length of the semester. At the beginning of the semester, a student registers for the courses that he/she wants to study and at the end of the semester a grade is awarded. On obtaining a pass grade, the student earns all the credits associated with the course while a fail grade does not get any credit; partial credits are not awarded. Each course is associated with a certain number of credits.

(a) Level of the course

The first digit of the numeric part of the course code indicates the level of the course as determined by the prerequisite course and/or by the maturity required for registering for the course.

2.3 Registration and Attendance

2.3.1 Registration

Registration is a very important procedural part of the academic system. The registration procedure ensures that the student's name is on the roll list of each course that he/she wants to study. No credit is given if the student attends a course for which he/she has not registered. Registration for courses to be taken in a particular semester will be done according to a specified schedule before the end of the previous semester. The student must also take steps to pay his/her dues before the beginning of the semester by a demand draft or by making use of internet banking facility of SBI. Students who do not make payments by a stipulated date will be de-registered for the particular semester. In absentia registration or registration after the specified date will be allowed only in rare cases at the discretion of the Dean (Academics). In case of illness or absence during registration, the student should intimate the same to his/her course advisor and Dean (Academics). A student must meet his/her advisor within the first week of the new semester for the confirmation of his/her registration. The registration record should be preserved until the semester grade card is received.

Various activities related to registration are listed below. The relevant dates are included in the Semester Schedule that is available before the start of the semester.

2.3.2 Registration and Student Status

Registration by a student confirms his/her status as a student at the Institute. Failure to register before the last date for late registration will imply that the student has discontinued studies and his/her name will be struck-off the rolls.

Every registered student is considered as a full-time student at the institute. They are expected to be present at the Institute and devote full time to academics.

2.3.3 Advice on Courses

At the time of registration, each student must consult his/her student advisor/programme coordinator to finalize the academic programme, keeping in view factors, such as, minimum/maximum numbers of total and lecture credits, past performance, backlog of courses, SGPA/CGPA, pre-requisite, work load and student's interests, amongst others. Special Provisions exist for academically weak students.

2.3.4 Registration Validation

Before the first day of classes, every student is required to be present on campus and validate his/her registration. The updated registration record will be available on the website and the hard copy will be available with the student's advisor. Students who do not do registration validation will not be permitted to add/drop courses.

2.3.5 Late Registration

Late registration is permitted under the following conditions:

(a) A student, who was not on campus during the period of registration in the previous semester, needs to complete the registration process on or before the first day of the semester before the commencement of classes.

or

(b) For reasons beyond his/her control, if a student is not able to register or send an authorized representative with a medical certificate, he/she may intimate prior through email to

aracademics@iitrpr.ac.in. He/She is required to apply to the Dean (Academics) for late registration. Dean (Academics) will consider and may approve late registration in genuine cases on payment of an extra fee called late registration fee. Late registration is permitted until one week after the start of the semester.

2.3.6 Add, Drop, Audit and Withdrawal from Courses

- a. Add/Drop: A student has the option to add a course (s) that he/she has not registered for, or drop a course (s) for which he/she has already registered for. This facility is restricted to the first week of the semester.
- b. Audit: A student may apply for changing a credit course to an audit one within one week of the end of the mid semester examination. Audit is not allowed in any 1st year course and also for any core course. The credit of the courses which are audited will not be counted in the final degree requirements.
- c. Withdrawal: A student who wants to withdraw from a course should apply within one week of the end of the mid semester examination. A withdrawal grade (W) will be awarded in such cases.

2.3.7 Semester Withdrawal

If a student is absent for more than 20 teaching days in a semester on medical grounds, he/she may apply for withdrawal for that semester, i.e., withdrawal from all courses registered in that semester. Application for semester withdrawal must be made as early as possible at least before the start of the major tests. Partial withdrawal from the courses registered in a semester is not allowed.

2.3.8 Registration and Fees Payment

Every registered student must pay the stipulated fees in full before the specified deadlines. In the event that a student does not make these payments, he/she will be de-registered from all courses and his/her name will be struck-off from the roll list.

2.3.9 Registration Record

In addition to web-based entries related to registration, the student should ensure that the same are entered on the Registration Record. Queries related to registration will be considered only when accompanied by the original Registration Record. This record must be preserved until the semester grade card is received by the student.

2.3.10 Continuous Absence and Registration Status

If a student is absent from the Institute for more than four weeks without notifying the Head of the Department or the Dean (Academics), his/her registration will be terminated and the name will be removed from the Institute rolls.

2.3.11 Attendance Rules

All students must attend every lecture, tutorial and practical class. However, to account for late registration, sickness or other such contingencies, the attendance requirement will be a minimum of 75% of the classes actually held. If a student has less than 75% attendance in a course during the semester, in lectures, tutorials and practicals taken together (as applicable), the course coordinator may award an 'F' grade in that course irrespective of his/her performance in the tests. For the purpose of attendance calculation, every scheduled lecture, tutorial or practical class will count as one unit irrespective of the number of contact hours. Attendance record will be maintained based upon roll calls (or any equivalent operation) in every scheduled lecture, tutorial and practical class. The course coordinator will maintain and consolidate attendance record for the course (lectures, tutorials and practical's together, as applicable). Students are required to attend lectures, laboratories, workshops, etc., and not to absent themselves without adequate reasons and prior permission. Applications for leave of absence are to be made in writing to the Head of the Department through the Faculty Advisor. Any type of absence for more than 10 days should be notified to the Academic Section immediately.

2.4 Rules and Regulations

2.4.1 Absence during the Semester

- (a) A student must inform the Dean (Academics) immediately of any instance of continuous absence from classes.
- (b) A student who is absent due to illness or any other emergency, up to a maximum of two weeks, should approach the course coordinator for make-up quizzes, assignments and laboratory work.
- (c) A student who has been absent from mid semester examination due to illness should approach the course coordinator for a make-up test immediately on return to class. The request should be supported with a medical certificate from institute's medical officer. A certificate from a registered medical practitioner will also be acceptable for a student normally residing off-campus provided registration number of the medical practitioner appears explicitly on the certificate.
- (d) In case of absence on medical grounds or other special circumstances, before or during the major examination period, the student can apply for I-grade. 75% attendance in a course is necessary for being eligible for an I-grade in that course. An application requesting I-grade should be made at the earliest but not later than the last day of major tests. The application should be made to the Head of the Department of the student's programme who will grant approval depending on the merit of the case and inform the course coordinators and UG section. The student should complete all the course requirements within ten days from the last day of the Major Tests. The I-grade will then be converted to a proper grade (A to F, NP or NF).
- (e) In special situations arising due to the inability to be present at the institute during the stipulated period, in (d) above, the period for conversion of I grade can be extended to the first week of the next semester. Approval for this extension can be granted by the Dean (Academics) on recommendations of the concerned Head of the Department and the course coordinators. A request to this effect must be included in the application for I-grade.
- (f) In case of the period of absence on medical grounds is more than 20 working days during the semester, a student may apply for withdrawal from the semester, i.e., withdrawal from all courses registered that semester. Such application must be made as early as possible and latest before the start of the major tests. No applications for semester withdrawal will be considered after the major tests have commenced. The Dean (Academics), depending on the merit of the case, will approve such applications. Partial withdrawal from courses registered in a semester is not allowed.
- (g) If a student is continuously absent from the institute for more than four weeks without notifying the Dean (Academics), his/her name will be removed from institute rolls.

2.4.2 Branch Change at the end of First Year

- a) A student is eligible to apply for change of branch at the end of first year only, provided he/she satisfies the following criteria:-
 - (i) CGPA for GE/OBC category student :- > 7.50 or greater
 - (ii) CGPA for SC/ST/PD category student :- > 6.50 or greater
 - (iii) Earned credits at the end of first academic session are 36 credits or more.
- b) Change of the branch will be permitted strictly in the order of merit , in each category as determined by CGPA at the end of the first year, subject to the limitation that the actual number of students in the third semester in the discipline to which the transfer is to be made should not exceed its sanctioned strength by more than 10% and the strength of the branch from which transfer is being sought does not fall below 85% of its sanctioned strength.
- c) The condition mentioned in item I-III above will not be insisted upon for a change to a branch in which a vacancy exists with the reference to the sanctioned strength and the concerned student was eligible as per JEE Rank for admission to that branch at the time of entry to IIT Ropar. However, these conditions will continue to apply in the case of students seeking change to a branch to which the concerned student was not eligible for admission at the time of entry to IIT Ropar.

2.4.3 Measures for Helping SC/ST Students

A number of measures exist for helping students belonging to SC and ST categories. A senior faculty member is appointed as advisor to SC/ST students for advising them on academic and non-academic matters. Financial measures for helping SC and ST student are also available.

2.5 Curriculum and Structure of the Bachelor of Technology Programmes

2.5.1 Programme and Credit Structure

There are four options for 4-Year UG Program as given below

S.No.	Options for 4 year UG program	Total credits required to complete the course	Remarks
1	"B.Tech." in an engineering major discipline.	145 Credits	
2	"B.Tech. with Minor" (minor in any other discipline than the major discipline)	160 Credits	(145 Credit B.Tech. +15 Credit minor course work)
3	"B.Tech. with Concentration" (concentration areas will be within the major discipline).	160 Credits	(145 credit B.Tech.+15 Credit concentration course work)
4	"B.Tech. with Honors".	170 Credits	(145 Credit B.Tech. +15 Credit Coursework + 10 Credit Honors Project). An honors student can opt for minor/concentration courses as part of the 15 credit coursework requirement of honors.

2.5.2 Credit Structure of the Basic B. Tech. Programme

Category	Credits Requirements	Remarks
Science Requirement Core (SR)	24	
Science Electives (SE)	6	
General Engineering Requirement (GR)	23.5	16 credits as GE core for each
Programme Core (PC)	36 to 42	Total 48 credits (PC+PE)
Programme Elective (PE)	6 to 12	
Humanities and Social Sciences (HS) core	15 (min)	
Humanities and Social Sciences (HS) Electives	6	
Capstone Projects	Total 9 credits	
· Development Engineering Project.	3	
· Capstone Project I	3	
· Capstone Project II	3	
Industrial Internship and Comprehensive Viva	3.5	
Extra - Curricular NCC/NSO/NSS	4 credits	
Open Electives	Total 6 credits	
· Open Electives I	3	
· OpenElectives II	3	
Graduation Requirements (GR)	145	

2.5.3 Overall Credit Structure for All the Four Options Given in 2.5.1

Total Credits	Basic B.Tech. (145)	B.Tech. with Concentration (160)	B.Tech. with Minor (160)
Maths + Science	30	30	30
Humanities & Social Sciences	21	21	21
General Engineering	23.5	23.5	23.5
Program Core + Electives	48	63	48
BTP + DE Capstone Projects	9	9	9
Internship + Comp. Viva	3.5	3.5	3.5
Open Electives	6	6	21
Extra -Curricular	4	4	4
Total	145	160	160
Honors Add -On		10	10

2.5.4 Credit Limits

The following credit limits may be adopted:

- (i) B.Tech. :19.5 Credits per semester
- (ii) B.Tech. with Minor : 22.5 credits per semester
- (iii) B.Tech. with Minor, Concentration, Honors, or 6-month internship in 8th sem: 24 Credits per semester

2.5.5 CGPA Requirement for Minor, Concentration, Honors, or “6-Month Internship”

The minimum CGPA for opting for Minor, Concentration, Honors, or 6-Month internship program is 7.5. It is needed to be maintained 7.5 CGPA in order to remain enrolled to the Minor, Concentration, Honors, or 6-Month Internship program.

2.5.6 Minimum CGPA for award of B. Tech. Degree

The minimum CGPA for award of the B. Tech. degree is 5.0

2.5.7 Special Requirements

Communication Skills

Every student will be required to make presentations in various courses and if the Department so feels, the student can be asked to take a regular course on this aspect for credit.

2.6 Performance Requirements and Monitoring

2.6.1 Maximum Period for Completing Degree Requirements

The maximum permitted duration of each programme is determined in terms of number of registered regular semesters, herein after called registered semesters. Any semester in which a student has registered for a course will be called registered semester subject to the following:

- (a) Only the first and second semesters of an academic year can be registered semesters. The summer semester will not be considered as a registered semester.
- (b) A semester when a student has been granted withdrawal or granted leave will not be considered as a registered semester.
- (c) The semester when a student is suspended from the Institute on disciplinary grounds will not be counted towards the number of registered semesters.

The summer semesters falling in between the permitted registered semesters shall be available for earning credits. After the student has registered for the maximum permissible number of registered semesters, the subsequent summer semesters will not be available for earning credits.

The maximum permissible number of registered semesters for completing all degree requirements for the B. Tech. degree is twelve (12). If a student opts for the slow-paced programme (as defined later), then the maximum permissible number of registered semesters shall be increased by two semesters.

2.6.2 Conditions for Termination of Registration, Probation and Warning

If the performance at the end of first two registered semesters is very poor, then registration will be terminated. If the performance is poor but not very poor, then the student will be given an option to start afresh. Rules for re-start/termination are given below.

- a) Student will be given a chance to re-start after the first two registered semesters if his/her total number of earned credits is less than or equal to 17 at the end of the second semester.
- b) If a student re-starts after the first two registered semesters, then his/her credits earned and semesters registered will not be carried over. The re-start will be indicated on the transcript. The re-start will be permitted only once. If at the end of two registered semesters after re-start, the earned credits are less than or equal to 17 then the registration will be terminated.
- c) Each student is expected to earn at least 9 credits in the first registered semester and 10.5 credits in each subsequent registered semester with an SGPA greater than or equal to 5.0. If the performance of a student at the end of the any registered semester is below this minimum acceptable level, then he/she will be placed on probation and a warning shall be given to him/her and intimation sent to the parents also.
- d) The student placed on probation shall be monitored, including mandatory attendance in classes, special tutorials and mentoring.
- e) If the performance of a student on probation does not meet the above criterion (c) in the following registered semester, then the student will be permitted to register only if the department makes a favorable recommendation. The Head of the Department's recommendation shall be prepared after consultation with the student, and will include (i) feasibility of completing the degree requirements, and (ii) identification or remedial measures for the problems leading to poor performance.
- f) The registration of any student is limited to 1.25 times the average earned credits of the previous two semesters, subject to a minimum of 8 credits and a maximum of 19.5 credits.

2.6.3 Slow-paced Programme

A student who has earned between 18 and 27 credits at the end of the first two registered semesters will be eligible to opt for the slow-paced programme. A student opting for such a programme shall be permitted two additional registered semesters for completing degree requirements.

In the slow paced programme, the upper limit for credits registered in a semester will be 12.5. A student in this programme is expected to earn at least 8 credits with minimum SGPA 5.0 in any semester, failing which he/she will be issued a warning and placed on probation.

- (a) The student placed on probation shall be regularly monitored. Ensuring mandatory attendance in classes, engaging special tutorials and mentoring will be some of the ways of monitoring.
- (b) If the performance of a student on probation does not meet the above criterion in the following registered semester, then the student should be permitted to register only if the department makes a favorable recommendation. The Head of the Department's recommendation shall be prepared after consultation with the student, and should include (i) feasibility of completing the programme, and (ii) identification of remedial measures for the problems leading to poor performance.

Such slow-paced programmes will be defined by the respective department for each student.

2.7 Selection of courses for the Basic B.Tech. in Civil Engineering / Chemical Engineering / Computer Science & Engineering /Electrical Engineering/Mechanical Engineering & Metallurgical & Materials Engineering.

Sr.No.	Courses	Detail of Courses/Credits
1.	HS Core (15 Credits)	<ul style="list-style-type: none"> • HS101 History of Technology (1.5) • HS103 Professional English Communication OR HS102 English Language Skills (3) • HS201 Economics (3) • HS301 Industrial Management (3) • HS104 Professional Ethics (1.5) • HS202 Human Geography and Societal Needs (3)
2.	HS Electives (6 Credits)	<ul style="list-style-type: none"> • HS Elective I (3)* • HS Elective II (3)* <p>*An English Language/Literature elective course in either 7th or 8th semester is required for the students who had "HS102 English Language Skills" in 1st Semester</p>
3.	Sciences Core (24 Credits)	<ul style="list-style-type: none"> • PH101 Physics for Engineers (3) • PH102 Physics for Engineers Lab (2) • CY101 Chemistry for Engineers (4) • MA101 Calculus (3) • MA102 Linear Algebra, Integral Transforms and Special Functions (3) • BM101 Biology for Engineers (3) • Program-Specific Science-Maths I (3) (viz. MA201 "Differential Equations" for all departments) • Program-Specific Science-Maths II (3) (viz. MA202 "Probability and Statistics" by CSE, ME, CE and MA203 ; "Probability and Stochastic Processes" by EE; a chemistry course CY230 "Introduction to Organic Chemistry and Biochemistry" by CH)
4.	Sciences Electives (6 Credits)	<ul style="list-style-type: none"> • Science - Maths Elective I (3) • Science Maths Elective II (3)

Sr.No.	Courses	Detail of Courses/Credits
5.	General Engineering (23.5 Credits)	<ul style="list-style-type: none"> • GE101 Technology Museum Lab (1) • GE102 Workshop Practice (2) • GE103 Introduction to Computer Programming & Data Structure (4.5) • GE104 Introduction to Electrical Eng (3) • GE105 Engineering Drawing (1.5) • GE106 Introduction to Engineering Products (1) • GE107 Tinkering Lab (1.5) • GE108 Basic Electronics (3) • Introduction to Environmental Science & Engineering (3) • Program-Specific General Engineering (3)* <p>*The following Program - Specific General Engineering courses by the departments: GE201 "Introduction to Materials Science & Engineering" for ME & CH, GE 106 "Materials Science for Electrical and Electronics Engineers" for EE, GE203 "Materials Science for Civil Engineers" for CE, and EE201 "Signals and Systems" for CSE</p>
6.	Program Core and Electives (total 48 Credits)	<ul style="list-style-type: none"> • Program Core (36 to 42 Credits) • Program Electives (6 to 12 Credits)
7.	Capstone Projects (9 Credits)	<ul style="list-style-type: none"> • Development Engineering Project (3) • Capstone Project I (3) • Capstone Project II (3)
8.	Industrial Internship and Comprehensive Viva (3.5 Credits)	<ul style="list-style-type: none"> • Industrial Internship and Comprehensive Viva Voce (3.5)
9.	Extra-Curricular (4 Credits)	<ul style="list-style-type: none"> • NC101 NCC I OR NO101 NSO I ORNS101 NSS I (1) • NC102 NCC II OR NO102 NSO II ORNS102 NSS II (1) • NCC III OR NSO III ORNSS III (1) • NCC IV ORNSO IV OR NSS IV (1)
10.	Open Electives (6 Credits)	<ul style="list-style-type: none"> • Open Elective I (3) • Open Elective II (3)
11.	Extra-Curricular (4 Credits)	Will be notified soon

2.8 Sequence of the courses for all the B.Tech. Programme

Most of the common core courses are planned to be run in both the semesters of the year, so that half of the students (half of the entire batch) study a course in one semester (August-November) and the rest half in the other (January-April).

Semester 1

Plan A (about 50% students)	Plan B (rest 50% students)
MA101 Calculus (3) [3-1-0-53]	
HS103 Professional English Communication (3) [2-2/3-2-13/3-3] OR HS102 English Language Skills (3) [2-2/3-2-13/3-3] instead, for students weak in English	
NC101 NCC I (1) [0-0-2-11] (NS101NSS I / NO101 NSO I only when NCC 1 not feasible for the student)	
PH101 Physics for Engineers (3) [3-1-0-5-3] PH102 Physics for Engineers Lab (2) [0-0-4-2-2]	CY101 Chemistry for Engineers (4) [3-1-2-6-4]
GE104 Introduction to Electrical Engineering (3) [2-2/3-2-13/3-3]	GE103 Introduction to Computer Programming & Data Structure (4.5) [3-0-3-15/2-4.5]
GE102 Workshop Practice (2) [0-0-4-2-2]	GE105 Engineering Drawing (1.5) [0-0-3-3/2-1.5]
HS101 History of Technology (1.5) [3/2-1/2-0-5/2-1.5]	GE 101 Technology Museum Lab (1) [0-0-2-1-1]
Total Credits 18.5/18	

Semester 2

Plan A (for those having Plan B in Sem 1)	Plan B (for those having Plan A in Sem 1)
MA102 Linear Algebra, Integral Transforms and Special Functions (3) [3-1-0-5-3]	
Program Core (3) (viz. ME101 "Engineering Mechanics" [3-1-0-5-3] for ME and CE, CH 101 "Introduction to Chemical Engineering" [3-1-0-5-3] for CH, CS101 "Discrete Mathematical Structures" [3-1-0-5-3] for CSE) OR Program-Specific General Engineering (3) (viz. "GE106 Materials Science for Electrical and Electronics Engineers" [3-1-0-5-3], for EE)	
NC102 NCC II (1) [0-0-2-1-1] NO102 NSO II (1) [0-0-2-1-1] NS102 NSS II (1) [0-0-2-1-1]	OR OR
CY101 Chemistry for Engineers (4) [3-1-2-6-4]	PH101 Physics for Engineers (3) [3-1-0-5-3] PH102 Physics for Engineers Lab (2) [0-0-4-2-2]
GE103 Introduction to Computer Programming & Data Structure (4.5) [3-1-3-13/2-4.5]	GE104 Introduction to Electrical Engineering (3) [2-2/3-2-13/3-3]
GE105 Engineering Drawing (1.5) [0-0-3-3/2-1.5]	GE102 Workshop Practice (2) [0-0-4-2-2]
GE101 Technology Museum Lab (1) [0-0-2-1-1]	HS 101 History of Technology (1.5) [3/2-1/2-0-5/2-1.5]
Total Credits 18/18.5	

Semester 3

Program-Specific Science-Maths I (3) [3-1-0-53] (viz. MA201 "Differential Equations (3) [3-1-0-5-3]" for CSE, ME, CE, CH, EE)
Program Core (8) (total 8 credits: max 6L, rest labs)
Program-Specific General Engineering (3) (viz. GE201 "Introduction to Materials Science and Engineering" [3-1-0-5-3], for ME and CH, GE203 "Materials Science for Civil Engineers" [3-1-0-5-3], for CE, and EE201 "Signals and Systems" (3) [3-1-0-5-3] for CSE) OR Program Core (3) (for EE)
NCC III (1) [0 -0-2-1-1] OR NSO III (1) [0 -0-2-1-1] OR NSS III (1) [0 -0-2-1-1]
HS201 Economics (3) [3-1-0-5-3] (about 50% students) OR GE108 Basic Electronics (3) [2-2/3-2-13/3-3] (for those not having Economics this sem)
GE107 Tinkering Lab (1.5)[0-0-3-3/2-1.5] (about 50% students) OR GE109 Introduction to Engineering Products (1) [0-0-2-1-1](for those not having Tinkering Lab this sem)
Total Credits 19.5

Semester 4

Program-Specific Science-Maths II (3) [3-1-0-5-3] (viz. MA202 "Probability and Statistics" for CSE, ME and CE; MA203 "Probability and Stochastic Processes" for EE, CY230 "Introduction to Organic Chemistry and Biochemistry" for CH)
Program Core (8) (total 8 credits: max 6L, rest labs)
HS202 Human Geography and Societal Needs (3) [1-1/3-4-1 1/3-3] (about 50% students) OR BM101 Biology for Engineers (3) [3 -1-0-5-3](for those not having Human Geography and Societal Needs this sem)
NCC IV (1) [0 -0-2-1-1] OR NSO IV (1) [0 -0-2-1-1] OR NSS IV (1) [0 -0-2-1-1]
GE108 Basic Electronics (3) [2-2/3-2-13/3-3] (for those who did not have it in 3rd sem) OR HS201 Economics (3) [3-1-0-5-3] (for those who did not have it in 3rd sem)
GE109 Introduction to Engineering Products (1) [0-0-2-1-1](for those who did not have it in 3rd sem) OR GE 107 Tinkering Lab (1.5)[0-0-3-3/2-1.5](for those who did not have it in 3rd sem)
Total Credits 19

Semester 5

Plan C	Plan D
BM101 Biology for Engineers (3) [3-1-0-5-3] (for those who did not have it in 4th sem) OR HS202 Human Geography and Societal Needs (3) [1-1/3-4-11/3-3](for those who did not have it in 4th sem)	
Introduction to Environmental Science & Engineering (3) [3-1-0-5-3] (about 50% students) OR HS 301 Industrial Management (3) [3-1-0-5-3] (for those not having Introduction to Environmental Science & Engineering this sem)	
HS104 Professional Ethics (1.5) [1-1/3-1-13/6-1.5] (about 50% students)	
Program Core (10.5) (total 10.5 credits: 8L max, rest labs) (for those having Professional Ethics this sem)	Program Core (12) (total 12 credits: 9L max, rest labs) (for those not having Professional Ethics this sem)
Total Credits 18	

* Civil Engineering students shall credit the course- Introduction to Environmental Science and Engineering in their fifth semester only.

Semester 6

Plan C (for those having Plan D in Sem 5)	Plan D (for those having Plan C in Sem 5)
Development Engineering Project (3) [0-0-6-3-3]	
HS 301 Industrial Management (3) [3-1-0-5-3] (for those who did not have it in 5th sem) OR Introduction to Environmental Science & Engineering (3) [3-1-0-5-3] (for those who did not have it in 5th sem)	
Program Core (0 to 6 credits) OR Program Elective (rest of 6 credits)	
	HS 104 Professional Ethics (1.5) [1-1/3-1-13/6-1.5] (for those who did not have it in 5th sem)
Program Core (6.5) (total 6.5 credits, 6L max, rest labs) (for those not having Professional Ethics this sem)	Program Core (5) (total 5 credits, 5L max, rest labs) (for those having Professional Ethics this sem)
Total Credits 18.5	

Summer Vacation following Semester 6

Industrial Internship and Comprehensive Viva Voce (3.5) (70% weightage for 8-week full internship and 30% for comprehensive viva on program fundamentals)
Total Credits 3.5

Semester 7

Capstone Project I (3) [0-0-6-3-3]
HS Elective I (3) (An English Language/Literature elective course in either 7th or 8th sem for students who had "English Language Skills" in 1st Semester)
Open Elective I (3)
Science-Maths Elective I (3)
Program Elective (3)
Total Credits 15

Semester 8

Capstone Project II (3) [0-0-6-3-3]
HSS Elective II (3) (An English Language/Literature elective course in either 7th or 8th sem for students who had "English Language Skills" in 1st Semester)
Open Elective II (3)
Science-Maths Elective II (3)
Program Elective (3)
Total Credits 15

Grand Total 145 Credits

- Contents of all the courses are available on www.iitrpr.ac.in as Course booklet of UG 2018-19

2.8.1 Course Plan for B.Tech. with Minor

Same as that for "Basic B.Tech." with Minor coursework (total 15 credits) added and distributed over four semesters - Semester 5 to 8.

2.8.2 Course Plan for B.Tech. with Concentration

Same as that for "Basic B.Tech." with Concentration coursework (total 15 credits) added and distributed over four semesters - Semester 5 to 8.

2.8.3 Course Plan for B.Tech. (Honors)

Same as that for "Basic B.Tech." with Honors coursework (total 15 credits) added and distributed over four semesters - Sem 5 to 8. Honors coursework may be the same as Minor or Concentration coursework.

2.8.4 Course Plan for Basic B.Tech. with Additional Internship

The coursework required for "Basic B.Tech." may be completed in first seven semesters. Additional Internship I to III [About 6 Months, Mid December to Mid June] may be opted during the last (eighth) semester. This option may be opted by the end of 4th semester.

2.8.5 Comparison of Different Options give in 2.5.1

Semester ==>>>	1	2	3	4	5	6	Summer between sem 6 and 7	7	8	Total Credits
HSS	Professional English Communication (3) + History of Technology (1.5)		Economics (3)	Human Geography and Societal Needs (3)	Professional Ethics (1.5)	Industrial Management (3)		HSS Elective I (3)	HSS Elective II (3)	21
Physics	Physics for Engineers (5)									5
Chemistry		Chemistry for Engineers (4)								4
Mathematics	Engineering Mathematics I (3)	Engineering Mathematics II (3)								6
Science -Maths			Program-Specific Science-Maths I (3)	Program-Specific Science-Maths II (3)				Science-Maths Elective I (3)	Science-Maths Elective II (3)	12
General Engineering	Intro to Electrical Eng (3) + Engineering Drawing (1.5)	Workshop(2) + Museum Lab (1) + Programming & Data Struct (4.5)	Program-specific General Engineering (3) + Tinkering Lab (1.5)	Intro to Engineering Products (1) + Basic Electronics (3)	Environmental Sc & Engg (3)					23.5
Projects (BTP + DE) + Internship + Comprehensive Viva						Development Engineering Project (3)	Industrial Internship & Comprehensive Viva (3.5)	BTP Capstone Project I (3)	BTP Capstone Project II (3)	12.5

Program Core (CSE / EE / ME / CE/CH)		Program Core (3)	Program Core (8)	Program Core (8)	Program Core (10.5)	Program Core (6.5) + Program Core and/or Electives (6)		Program Elective (3)	Program Elective (3)	48
Honors (CSE / EE / ME / CE/CH)								Honors Project 1 (5)	Honors Project 2 (5)	10
Extra - Curricular	NCC/NSS/NSO I (1)	NCC/NSS/N SO II (1)	NCC/NSS/N SO III (1)	NCC/NSS/N SO IV (1)						4
Biology					Biology for Engineers (3)					3
Minor / Concentration / Honors Related Open Elective					Minor / Concentration / Honors Related Coursework (4)	Minor / Concentration / Honors Related Coursework (4)		Minor / Concentration / Honors Related Coursework (4)	Minor / Concentration / Honors Related Coursework (3)	15
Open Electives								Open Elective I (3)	Open Elective II (3)	6
Total credits (B.Tech.+Minors +Honors)	18	18.5	19.5	19	22	22.5	3.5	24	23	170
Total credits (B.Tech.+Minor)	18	18.5	19.5	19	22	22.5	3.5	19	18	160
Total credits (B.Tech.)	18	18.5	19.5	19	18	18.5	3.5	15	15	145

2.9 B.Tech. - M.Tech. Dual Degree in Mechanical Engineering

Credit structure of the programme

- i) Duration of the programme: 5 years (10 semesters)
- ii) Total No. of credits requirements: 183

UG Level Credits	133
PG Level Credits	50
Total credits	183

As per the below provided sequence of courses, the students of the B.Tech.-M.Tech. (Dual degree) programme spend their first six semesters doing undergraduate courses, primarily, together with the B.Tech. students. The students complete six graduate level courses in seventh and eighth semester, while ninth and tenth semesters are spent doing MTech project work.

At the end of five years, they graduate, receiving both B.Tech. and M.Tech. Degrees together. There is no option of early exit with a B.Tech. degree only unless the student's performance is so poor that he/she is considered incapable of securing the higher degree. Institute reserves the sole right to make the decision in such cases. The course detail will be shared soon.

2.10 Sequence of Courses for B.Tech.-M.Tech. Dual Degree program of Mechanical Engineering

Semester 1

Plan A (about 50% students)	Plan B (rest 50% students)
MA101 Calculus (3) [3-1-0-5-3]	
HS103 Professional English Communication (3) [2-2/3-2-13/3-3] OR HS102 English Language Skills (3) [2-2/3-2-13/3-3] instead, for students weak in English	
NC101 NCC I (1) [0-0-2-1-1] (NS101NSS I / NO101 NSO I only when NCC 1 not feasible for the student)	
PH101 Physics for Engineers (3) [3-1-0-5-3] PH102 Physics for Engineers Lab (2) [0-0-4-2-2]	CY101 Chemistry for Engineers (4) [3-1-2-6-4]
GE104 Introduction to Electrical Engineering (3) [2-2/3-2-13/3-3]	GE103 Introduction to Computer Programming & Data Structure (4.5) [3-0-3-15/2-4.5]
GE105 Engineering Drawing (1.5) [0-0-3-3/2-1.5]	GE102 Workshop Practice (2) [0-0-4-2-2]
HS101 History of Technology (1.5) [3/2-1/2-0-5/2-1.5]	GE101 Technology Museum Lab (1) [0-0-2-1-1]
Total Credits 18.5/18	

Semester 2

Plan A (for those having Plan B in Sem 1)	Plan B (for those having Plan A in Sem 1)
MA102 Linear Algebra, Integral Transforms and Special Functions (3) [3-1-0-5-3]	
ME101 Engineering Mechanics (3) [3-1-0-5-3]	
NC102 NCC II (1) [0-0-2-1-1] OR NO102 NSO II (1) [0-0-2-1-1] OR NS102 NSS II (1) [0-0-2-1-1]	
CY101 Chemistry for Engineers (4) [3-1-2-6-4]	PH101 Physics for Engineers (3) [3-1-0-5-3] PH102 Physics for Engineers Lab (2) [0-0-4-2-2]
GE103 Introduction to Computer Programming & Data Structure (4.5) [3-1-3-13/2-4.5]	GE104 Introduction to Electrical Engineering (3) [2-2/3-2-13/3-3]
GE102 Workshop Practice (2) [0-0-4-2-2]	GE105 Engineering Drawing (1.5) [0-0-3-3/2-1.5]
GE101 Technology Museum Lab (1) [0-0-2-1-1]	HS101 History of Technology (1.5) [3/2-1/2-0-5/2-1.5]
Total Credits 18/18.5	

Semester 3

MA201 Differential Equations (3) [3-1-0-5-3]
ME102 Thermodynamics (3) [3-1-0-5-3] ME201 Solid Mechanics (3) [3-1-0-5-3] ME202 Machine Drawing (2) [0-0-4-2-2]
GE201 Introduction to Materials Science and Engineering (3) [3-1-0-5-3]
NCC III (1) [0-0-2-1-1] OR NSO III (1) [0-0-2-1-1] OR NSS III (1) [0-0-2-1-1]
HS201 Economics (3) [3-1-0-5-3] (about 50% students) OR GE108 Basic Electronics (3) [2-2/3-2-13/3-3] (for those not having Economics this sem)
GE107 Tinkering Lab (1.5) [0-0-3-3/2-1.5] (about 50% students) OR GE109 Introduction to Engineering Products (1) [0-0-2-1-1] (for those not having Tinkering Lab this sem)
Total Credits 19.5

Semester 4

MA202 Probability and Statistics (3) [3-1-0-5-3]
ME203 Theory of Machines (3) [3-1-0-5-3]
ME204 Fluid Mechanics (3) [3-1-0-5-3]
ME205 Design Lab-I (2) [0-0-4-2-2]
Human Geography and Societal Needs (3) [1-1/3-4-11/3-3] (about 50% students) OR BM101 Biology for Engineers (3) [3 -1-0-5-3](for those not having Human Geography and Societal Needs this sem)
NCC IV (1) [0-0-2-1-1] OR NSO IV (1) [0-0-2-1-1] OR NSS IV (1) [0-0-2-1-1]
GE108 Basic Electronics (3) [2-2/3-2-13/3-3] (for those who did not have it in 3rd sem) OR HS201 Economics (3) [3-1-0-5-3] (for those who did not have it in 3rd sem)
GE109 Introduction to Engineering Products (1) [0 -0-2-1-1](for those who did not have it in 3rd sem) OR GE107 Tinkering Lab (1.5)[0-0-3-3/2-1.5](for those who did not have it in 3rd sem)
Total Credits 19

Semester 5

Plan C	Plan D
BM101 Biology for Engineers (3) [3-1-0-5-3] (for those who did not have it in 4th sem) OR HS 202 Human Geography and Societal Needs (3) [1-1/3-4-11/3-3](for those who did not have it in 4th sem)	
Introduction to Environmental Science & Engineering (3) [2-2/3-2-13/3-3] (about 50% students) OR HS301 Industrial Management (3) [3-1-0-5-3] (for those not having Introduction to Environmental Science & Engineering this sem)	
ME206 Manufacturing Technology-I (3) [3-1-0-5-3] ME207 Manufacturing Lab-I (2) [0-0-4-2-2] ME301 Vibrations and Control (3) [3-1-0-5-3] ME302 Heat and Mass Transfer (3) [3-1-0-5-3] ME303 Thermo-Fluids Lab-I (1) [0-0-2-1-1]	
Open Elective - I (3)	
Total Credits 18	

Semester 6

Plan C (for those having Plan C in Sem 5)	Plan D (for those having Plan D in Sem 5)
Development Engineering Project (3) [0-0-6-3-3]	
HS301 Industrial Management (3) [3-1-0-5-3] (for those who did not have it in 5th sem) OR Introduction to Environmental Science & Engineering (3) [2-2/3-2-13/3-3] (for those who did not have it in 5th sem)	
HS104 Professional Ethics (1.5) [1-1/3-1-13/6-1.5]	
ME304 Machine Design (3) [3-1-0-5-3] ME305 Manufacturing Technology-II (3) [3-1-0-5-3] ME306 Design Lab-II (1.5) [0-0-3-1.5-1.5] ME307 Thermo-Fluids Lab-II (1.5) [0-0-3-1.5-1.5] ME308 Manufacturing Lab-II (2) [0-0-4-2-2]	
Open Elective - II (3)	
Total Credits 18.5	

Summer Vacation following Semester 6

Industrial Internship and Comprehensive Viva Voce (3.5) (70% weightage for 8 week full internship and 30% for comprehensive viva on program fundamentals)

Total Credits 3.5

Semester 7

PG Level Program Elective I (3)
HSS Elective I (3) (An English Language/Literature elective course in either 7th or 8th sem for students who had English Language Skills in 1st Semester)
PG Level Program Elective II (3)
Science-Maths Elective I (3)
PG Level Open Elective I (3)
Total Credits 15

Semester 8

PG Level Program Elective III (3)
HSS Elective II (3) (An English Language/Literature elective course in either 7th or 8th sem for students who had "English Language Skills" in 1st Semester)
PG Level Program Elective IV (3)
Science-Maths Elective II (3)
PG Level Open Elective II (3)
Total Credits 15

Semester 9

Project Part-1 (16 credits)

Total Credits 16

Semester 10

Project Part-2 (16 credits)

Total Credits 16

3 Fees

3.1 Mode of Payment

(a) **Institute dues**

All Institute dues are to be paid through Demand Draft in favour of "IIT Ropar Fee account, IIT Ropar" payable at Ropar or through State Bank of India Internet Banking as available.

(b) **Mess dues**

Mess dues are to be paid by demand draft in favour of "The Director, IIT Ropar, Hostel Account" payable at Ropar or State Bank of India Internet Banking as available.

3.2 Deadlines for Payment

(a) **Institute dues**

(i) All Institute dues to be paid in full before the last date for Late Registration (this is typically one week after the first day of classes).

(ii) Students who do not pay the required amount by this date, or those who make partial payments, shall have their registration cancelled. Registration will be restored on payment of fees and a fine as stipulated in the Institute rules.

(iii) In case of new entrants, the fees has to be paid by demand draft on the day of registration at the time of joining the Institute.

(b) **Mess dues**

All Mess dues are to be paid on or before the date for Registration Validation, i.e. before the first day of classes.

3.3 Refund of Fees

The whole amount of fees/other charges deposited by the students will be refundable after deduction of Rs. 1,000/, if the students do not join the programme after paying the dues and leave the Institute by applying for refund on or before the date of registration. No refund of fees will be permissible to students who have registered for the programme but leave immediately thereafter. In such cases, only caution money will be refunded and that too only at the end of the semester.

3.4 Withdrawal from the Institute

If a student is continuously absent from the Institute for more than four weeks without informing the Dean (Academics), his/her name will be removed from the Institute rolls. Such absence during the first year will render the B.Tech. student ineligible for re-admission.

A B.Tech. student wishing to leave the Institute on his/her own should submit an application duly countersigned by his/her father/guardian. He/she shall also obtain "Clearance Certificate" from the Department, the Librarian, the Warden, the Officer Commanding, NCC, and the Accounts Section, and submit to the Academics Section (UG) for settling his/her accounts in the Accounts Section. The student shall remain liable to pay all dues till the date on which his/her name is formally struck off the Institute rolls.

3.5 Transcripts, Degree and other Certificates

Additional transcripts, duplicate degrees/diplomas, etc can be obtained on payment of the following charges:

a) Degree, in person		: Rs.1000
b) Degree, in absentia	(In India)	: Rs.1000
	(In Abroad)	: Rs.1500
	Or	: US\$150
c) Migration Certificate (Only one original)		: Rs.500
d) Duplicate Degree/certificate (Only one Original)	(In India)	: Rs.2500
	(In Abroad)	: US\$250
e) Transcripts (1 Original + 4 Attested Copies)	(In India)	: Rs.500
	(In Abroad)	: US\$50
f) Duplicate Identity Card		: Rs.500
g) Certificate of medium of instruction in English (Only one original)	(In India)	: Rs.100
	(In Abroad)	: US\$10
h) Verification of degree certificate, JEE Rank, membership of Institute bodies, etc. (for each individual verification)	(In India)	: Rs.1000
	(In Abroad)	: US\$100
i) Character Certificate (only one original)	(In India)	: Rs.100
	(In Abroad)	: US\$10

3.6 Details of Semester Fees for the Academic Year 2018-19.

Sr.No.	Particulars	Amount
1	SEMESTER FEES	(INR)
1.1	INSTITUTE FEES	
	i) Tuition Fee	100000
	ii) Examination Fee	350
	iii) Registration/Enrolment Fee	250
	iv) Gymkhana Fee	500
	v) Medical Fee	50
	vi) Laboratory & other facilities	1500
	vii) Library	500
	viii) Hostel & Mess Establishment charges	1000
1.2	HOSTEL FEES +	
	i) Hostel Seat Rent	1000
	ii) Fan, Electricity and water charges	1000
	TOTAL (Semester Fees to be paid)	106150
2	ONE TIME PAYMENTS (Non-Refundable)	
	To be paid at the time of admission.	
	i) Admission Fees	200
	ii) GradeCard	200
	iii) Provisional Certificate	200
	iv) Student Welfare Fund	300
	v) Modernization Fees	400
	vi) Identity card	100
	vii) Benevolent fund	100
	viii) Alumni fees	1000
	ix) Training and Placement	500
	Total (one time payment at the time of admission)	3000
3	Deposits (Refundable)	
	i) Institute security deposit	
	ii) Library security deposit	2000
4	OTHER PAYMENTS	2000
	Insurance scheme (to be paid every year in 1st semester)	500
	TOTAL FEES	113650

The fee payable at IIT Ropar is subject to change as per the Institute rules.

Note :

- I) All SC and ST students will get 100% tuition fee exemption.
- II) The *backward students (whose family income is less than Rs.1 lakh per annum, shall get full remission of the tuition fee).
- III) The *other economically backward students (whose family income is between Rs.1 lakh to Rs.5 lakh per annum, shall get remission of 2/3rd of the tuition fee.

* This has no reference to the caste category of the students

+Mess charges will be notified separately.

4 Discipline and Attendance

4.1 Discipline

- (a) Students are expected to dress and to conduct themselves in a proper manner.
- (b) All forms of ragging are prohibited. If any incident of ragging comes to the notice of the authorities, the student concerned shall be given the opportunity to explain. If the explanation is not found to be satisfactory, the authorities can expel him/her from the Institute.
- (c) The students are expected to conduct themselves in a manner that provides a safe working environment for women. Sexual harassment of any kind is unacceptable and will attract appropriate disciplinary action.

4.2 Punishment to the students who indulge in unfair means during quizzes/mid semester/end-semester examinations .

The following graded punishments will be imposed on those who indulge in Academic Mal-practices – unfair means during Mid-semester/End-semester examinations:

(a) For rude behaviour

- (i) Severe warning shall be issued to a student who is found to display rude behaviour towards fellow students /invigilators.
- (ii) The student is liable to be expelled from the examination hall.
- (iii) In such cases, the parents of that student would be informed of such indiscipline.

(b) Malpractices and corresponding Punishments

S.No.	Nature of Malpractice	Recommended Punishment
1	Communicating with neighbours in the examination hall.	The erring student(s) shall be awarded 'F' grade in the subject concerned.
2.	Possessing incriminating* materials inside the examination hall. (or) Possessing the answer book of another candidate. (or) Passing on answer book to another student. (or) Exchange of question papers, with some answers noted down on them. (or) Individual referral of material/discussion with other students, during visit outside the examination hall.	The Disciplinary Committee shall have the discretion to recommend one of the following punishments: (a) The erring students(s) shall be awarded 'F' grade in the subject concerned. (or) (b) The erring student(s) shall be awarded 'F' grade in the subject concerned and one grade less in all the other subjects in the concerned semester. (or) (c) The concerned student(s) shall be awarded 'F' grade in all the subjects in the concerned semester.
3.	Involved in malpractice in the examination for the second time, in a premeditated manner.	The concerned student i) shall be awarded 'F' grade in all subjects, in the concerned semester and ii) shall be debarred from attending classes and taking examinations in the subsequent semester.
4.	Impersonation in the examination.	The concerned student i) shall be awarded 'F' grade in all subjects, in the concerned semester and ii) shall be debarred from attending classes and taking examinations in the next two subsequent semesters.

(* incriminating materials include written/printed material; unauthorized additional sheets without or with write-ups, bits, scribbles on scales / handkerchief / on the body; abuse of calculator / organizer / cell phone, etc.)

5 INDIAN INSTITUTE OF TECHNOLOGY ROPAR, PUNJAB

The Honour Code

I, Entry No.....

Do hereby undertake that as a student of IIT Ropar, Punjab:

1. I will not give or receive aid in examination; that I will not give or receive unpermitted aid in classwork, in preparation of reports or in other work that is to be used by the instructor as the basis of grading; and
2. I will do my share and take an active part in seeing to it that others as well as I uphold the spirit and letter of the Honour Code.
3. I realize that some examples of misconduct which are regarded as being in violation of the Honour Code include:
 - Copying from another's examination paper or allowing another to copy from one's own paper;
 - Unpermitted collaboration;
 - Plagiarism;
 - Revising and resubmitting a marked quiz or examination paper for regarding without t h e instructor's knowledge and concern;
 - Giving or receiving unpermitted aid on take home examination;
 - Representing as one's own work the work of another, including information available on the internet;
 - Giving or receiving aid on academic assignments under circumstances in which a responsible person should have known that such aid was not permitted; and
 - Committing a cyber offence such as breaking passwords and accounts, sharing passwords, electronic copying, planting viruses etc.

I accept that any act of mine that can be considered to be an Honour Code violation will invite disciplinary action.

Date:.....

Student's Signature.....

Name:.....

Entry No:

6 Academic Integrity

1. Cases of ethical lapses emanating from institutions of scientific research are increasingly being reported in the news. In this context, we need to create awareness and come up with a set of clear guidelines to maintain academic integrity. A flourishing academic environment entails individual and community responsibility for doing so. The three broad categories of improper academic behavior that will be considered are: I) plagiarism, II) cheating and III) conflict of interest.
2. Cases of ethical plagiarism are the use of material, ideas, figures, code or data without appropriate acknowledgment or permission (in some cases) of the original source. This may involve submission of material, verbatim or paraphrased, that is authored by another person or published earlier by oneself. Examples of plagiarism include:
 - (a) Reproducing, in whole or part, text/sentences from a report, book, thesis, publication or internet.
 - (b) Reproducing one's own previously published data, illustrations, figures, images, or someone else's data, etc.
 - (c) Taking material from class-notes or downloading material from internet sites, and incorporating it in one's class reports, presentations, manuscripts or thesis without citing the original source.
 - (d) Self-plagiarism, which constitutes copying verbatim from one's own earlier published work in a journal or conference proceedings without appropriate citations.
The resources given in Subsection (8) explain how to carry out proper referencing, as well as examples of plagiarism and how to avoid it.
3. Cheating is another form of unacceptable academic behavior and may be classified into different categories:
 - (a) Copying during exams, and copying of homework assignments, term papers or manuscripts.
 - (b) Allowing or facilitating copying, or writing a report or exam for someone else.
 - (c) Using unauthorized material, copying, collaborating when not authorized, and purchasing or borrowing papers or material from various sources.
 - (d) Fabricating (making up) or falsifying (manipulating) data and reporting them in thesis and publications.
4. Some guidelines for academic conduct are provided below to guard against negligence as well as deliberate dishonesty:
 - (a) Use proper methodology for experiments and computational work. Accurately describe and compile data.
 - (b) Carefully record and save primary and secondary data such as original pictures, instrument data readouts, laboratory notebooks, and computer folders. There should be minimal digital manipulation of images/photos; the original version should be saved for later scrutiny, if required, and the changes made should be clearly described.
 - (c) Ensure robust reproducibility and statistical analysis of experiments and simulations. It is important to be truthful about the data and not to omit some data points to make an impressive figure (commonly known as "cherry picking").
 - (d) Lab notebooks must be well maintained in bound notebooks with printed page numbers to enable checking later during publications or patent. Date should be indicated on each page.
 - (e) Write clearly in your own words. It is necessary to resist the temptation to "copy and paste" from the Internet or other sources for class assignments, manuscripts and thesis.
 - (f) Give due credit to previous reports, methods, computer programs etc. with appropriate citations. Material taken from your own published work should also be cited; as mentioned above, it will be considered self-plagiarism otherwise.
5. A clash of personal or private interests with professional activities can lead to a potential conflict of interest, in diverse activities such as teaching, research, publication, work on committees, research funding and consultancy. It is necessary to protect actual professional independence, objectivity and commitment, and also to avoid an appearance of any impropriety arising from conflicts of interest. Conflict of interest is not restricted to personal financial gain; it extends to a large gamut of professional academic activities including peer reviewing, serving on various committees, which may, for example, oversee funding or

give recognition, as well as influencing public policy. To promote transparency and enhance credibility, potential conflicts of interests must be disclosed in writing to appropriate authorities, so that a considered decision can be made on a case-by-case basis. Some additional information is available in the section below dealing with resources.

6. The responsibility varies with the role one plays.
 - (a) Student roles: Before submitting a thesis to the department, the student is responsible for checking the thesis for plagiarism using software that is available on the web. In addition, the student should certify that they are aware of the academic guidelines of the institute, have checked their document for plagiarism, and that the thesis is original work. A web-check does not necessarily rule out plagiarism.
 - (b) Faculty should ensure that proper methods are followed for experiments, computations and theoretical developments, and that data are properly recorded and saved for future reference. In addition, they should review manuscripts and theses carefully. Apart from the student certification regarding a web-check for plagiarism for theses, the Institute will provide some commercial software at SERC for plagiarism checking. Faculty members are encouraged to use this facility for checking reports, theses and manuscripts. Faculty members are also responsible for ensuring personal compliance with the above broad issues relating to academic integrity.
 - (c) A breach of academic integrity is a serious offence with long lasting consequences for both the individual and the institute, and this can lead to various sections. In the case of a student, the first violation of academic breach will lead to a warning and/or an "F" course grade. A repeat offence, if deemed sufficiently serious, could lead to expulsion. It is recommended that faculty members bring any academic violations to the notice of the Department Chairman. Upon receipt of reports of scientific misconduct, the Director may appoint a committee to investigate the matter and suggest appropriate measures on a case to case basis.
7. The Indian Institute of Technology Ropar will own the Intellectual Property (IP) made or created by any student carrying out research under the supervision of any employee of the Institute, or the IP developed individually by the student in the course of his/her studies at IIT Ropar, or with any use of IIT Ropar facilities. By accepting admission to IIT Ropar, a student agrees to assign to the IIT Ropar all such IP made or created at IIT Ropar, including inventions and copyright-able material; and to execute all papers required to assign, apply for, obtain, maintain, issue and enforce IP and IP rights.
8. References:
 - i. National Academy of Sciences article "On being a scientist,"
http://www.nap.edu/openbook.php?record_id=4917&page=RI
 - ii. <http://www.admin.cam.ac.uk/univ/plagiarism/>
 - iii. <http://www.aresearchguide.com/6plagiar.html>
 - iv. <https://www.indiana.edu/~tedfrick/plagiarism>
 - v. <http://www.files.chem.vt.edu/chem-ed/ethics/index.html>
 - vi. http://www.ncusd203.org/central/html/where/plagiarism_stoppers.html
 - vii. <http://sja.ucdavis.edu/files/plagiarism.pdf>
 - viii. <http://web.mit.edu/academicintegrity/>
 - ix. <http://www.northwestern.edu/provost/students/integrity/>
 - x. <http://www.ais.up.ac.za/plagiarism/websources.htm#info>
 - xi. <http://ori.dhhs.gov/>
 - xii. <http://www.scientificvalues.org/ceses.html>

7 Scholarships and Fellowships

7.1 Scholarship for B.Tech. Students

7.1.1 Institute Merit-cum-Means (MCM) Scholarships

The Institute offers Merit-cum-Means scholarships to under-graduate students in engineering and technology. These are permissible to about 25% of the students. The present value of Merit-cum-Means scholarship is Rs. 1000 per month for general category students and the recipient is exempted from paying tuition fee. 4-year B.Tech. students are eligible to receive Merit-cum-Means scholarship at the time of joining the Institute. The criterion of merit for the first year is All India Rank (AIR) in the JEE. The scholarships are renewed on a yearly basis until he/she clears all academic requirements of the programme, provided that he/she continues to satisfy the eligibility and continuation criteria.

For continuation of MCM, the performance of the students will be reviewed at the end of each semester. The first such review will be held at the end of the second semester.

Continuation of MCM Scholarship: For the general category students, the requirements of merit for the continuation of Institute Merit-cum-Means Scholarship are:

- CGPA must be 6.0 more; and
- Earned credits should not less than 20 times the number of semesters registered for;
- SGPA in the previous semester must be 6.0 or more.

On the criterion of means, only those students are presently eligible whose parents have a gross yearly income up to Rs. 4.5 lacs per annum. This criterion is applicable for all categories of students including SC/ST students. The terms and conditions of the award of the scholarship are laid down in the rules and regulations thereof in force and are subject to change from time to time.

7.1.2 Institute Merit Prizes and Certificates

The Institute offers merit prizes and certificates to the top 7% of the students of each 4-year B.Tech. Programme for the 1st and 2nd semester. The value of merit prize is Rs. 2500. The rules are as follows

1. For Merit Prizes and Certificates, the top 7% of the students admitted or sanctioned capacity whichever is less will be eligible in order of merit. In case the 7% limit is exceeded by virtue of more than one student having same merit, those students will also be eligible for these awards. The students having SGPA/CGPA less than 8.50 will not be considered for the award of merit prizes and certificates.
2. If 7% departmental strength is less than one, the students with highest CGPA subject to minimum 8.5 will be awarded the merit prizes of Rs.2500/-.
3. A prize of Rs.2500/- will be paid to all students entitled to merit prizes. This will be in addition to any scholarship that student may receive from any source whatsoever.
4. The award will be given to top 7% of the students each semester based on their SGPA in the previous semester.
5. The award of 1st year students will be given in 2nd semester based on their performance in 1st semester.
6. There will be common merit list of all students for the first year students. The merit list from 2nd to 5th year will be made discipline wise.
7. Any student except final semester, having less than 18 earned credits in the semester under consideration will not be eligible for merit prizes. All the credits of courses repeated by the student in the semester under consideration will not count towards the 18 earned credits mentioned above.
8. All graduating students subject to 7% limit will be considered eligible for awards on SGPA basis obtained during 8th/10th semester. In case of a tie, merit prize will be awarded to the student with higher CGPA.

7.1.3 Institute Free Studentship

The Institute offers free studentship to 10% of the students on the basis of means alone. The recipient is exempted from paying tuition fee. Students who are not eligible for the award of MCM Scholarship on the basis of their parent's income will not be considered eligible for the award of Free Studentship Scholarship. For continuation of Free studentship, the scholar must have to maintain the following criteria:

1. CGPA must be 6.0 more; and
2. Earned credits should not less than 20 times the number of semesters registered for;
3. SGPA in the previous semester must be 6.0 or more.

On the criterion of means, only those students are presently eligible whose parents have a gross yearly income up to Rs. 4.5 lac per annum. This criterion is applicable for all categories of students including SC/ST students. The terms and conditions of the award of the scholarship are laid down in the rules and regulations thereof in force and are subject to change from time to time.

7.1.4 Scholarship provision for Students of SC/ST Category

- (a) Tuition fee exemption is admissible to all SC/ST students irrespective of their parents/guardians income.
- (b) The Institute offers a scholarship of Rs. 300/- per month and exemption from paying room rent of the hostel, only to those SC/ST students whose parent'/guardians' income does not exceed the limit prescribed by the Government of India from time to time for the award of Merit-cum-Means scholarship. The students can opt for free mess facilities (basic menu) and Rs. 250/- per month as pocket allowance in lieu of the amount of the scholarship.

All the eligible SC/ST students while on training or doing courses during semester breaks or required to stay in the Institute during the semester breaks or exempted to take meals from the hostel due to medical reasons etc. may be given a payment of Rs. 70/- as pocket allowance (per month) and a per diem allowance in lieu of free mess facilities on the basis of prevalent average rate of mess charges as applicable from time to time.

- (c) Where an SC/ST candidate fails in the examination for the first time, the award may be renewed subject to a maximum limit of 5 years.

7.1.5 Post-Matric Scholarship

The SC/ST students can opt for Post Matric Scholarship offered to them by the State Government. For further details, Students can visit respective State Government website.

7.2 Top Class Education Scholarship for SC/ST students

The student can opt for this scholarship awarded by Government of India. Students are required to apply for this scholarship to www.scholarships.gov.in, IIT Ropar.

7.3 Other Scholarship

In addition to above mentioned scholarships there are few other scholarships awarded by NGO's, some external agencies and State Government.

7.4 Scholarship for B.Tech. - M.Tech. Dual Degree

Students belong to B.Tech.-M.Tech. dual degree programme who have good academic performance are given a scholarship in the final year, which is at par with that given to students of M.Tech. programmes.

NOTE:

For all the scholarships only affidavit on a judicial stamp paper of Rs 20/- duly signed by Magistrate / S.D.O/B.D.O / Tehsildar / Revenue Officer of his/her Jurisdiction as per requisite proforma in support of income proof / Income Tax Return / Income Certificate will be acceptable.

8 Library Facilities

The Central Library functions as the primary information resource centre and repository of printed and electronic resources for teaching and research activities at the institute. Apart from textbooks and recommended reading materials prescribed for each course offered at the institute, the library houses a growing collection of research monographs, reports, multi-volume reference works, dictionaries, encyclopedias, handbooks, and so on. The library facilitates access to electronic journals through its participation in consortia, such as E-Shodh Sindhu. The library also subscribes to several e-journals directly from publishers as well as through reputed subscription agencies. At present, users can consult more than 17000 books (available on shelves) and thousands of electronic books, journals. Online access is also provided to economic and political databases, scientometric databases such as Scopus, MathSciNet, and Web of Science.

The library operations are automated using LIBSYS 7 (EJB Version) software. The Online Public Access Catalogue (OPAC) which is on public domain enables users to search documents in possession of the library. The library is using the Radio Frequency Identification Technology (RFID), a state-of-the-art auto identification technique which helps in self-servicing and enhanced security. A separate e-resources section is provided in the library to browse CDs and DVDs of books, theses, and dissertations. The library has developed institutional digital repository (IDR) using open source software (DSpace) to archive and provide online access to the intellectual output of the institute. IDR is available publicly. These steps will greatly enhance the library's efficiency in making the resources available to the academic community at large and also enable the institute to participate in various inter-library initiatives at national and international levels.

Our Library is providing extensive research support services such as citation analysis, usage of reference management tools, copyright and plagiarism support etc. We are using a Turnitin, a leading academic plagiarism tool to improve the quality of research publications. Library is constantly striving to identify and adopt the emerging academic and research support tools and helping the institute in achieving its vision and mission.

9 Health Care

The Institute Medical Centre is located in a separate building adjoining the hostel complex. Several doctors, pharmacist, and staff nurse have been appointed to attend to campus residents in case of medical emergency. A state of the art ambulance for medical emergencies is available. In addition, the Institute relies on the friendly support of a few super-specialty hospitals in the city of Ropar, Mohali and Chandigarh for providing state-of-the-art medical care to its members.

10 Hostel and Dining Facilities

The Institute campus houses seven hostels with latest and modern facilities:- Jupiter, Mercury (Wing A, Wing B and Wing C), Neptune Hostels for boys, H1 and H2 for Boys and Venus, quarters and Guest house for girls. The Institute can accommodate 1360 boys and 274 girls students in its various campus hostels i.e Transit Campus-I, Transit campus-II and Permanent Campus. Out of these, three are new hostels (two for boys and one for girls) accommodating 600 students in the Permanent campus. All hostels are provided with excellent drinking water facilities. Each hostel has common facilities indoor, recreation and games. The hostel complex also includes a few shops that cater to the basic needs of the residents. IIT Ropar also provides gymnasium facility within its campus for its students. Lush green IIT campus add enormous fuel in the daily life of the students. We have lively and enchanting campus life wherein the students are provided with all the amenities for the

recreational activities. Here at IIT Ropar students rejuvenate their hidden talent and relive their hobbies. State of the art classroom with Audio visual aids and state of the art laboratories with latest research facilities enhance the teaching-learning process while Hightech library with tremendous books, journals, periodicals etc helps them to connect with the entire word of information and knowledge. At IIT Ropar, Students relish research and extracurricular activities to grow as an aspiring engineer with moral and ethical integrity.

11 Student Activities

The Institute has a Society for Publication and Communication Skills Development. In addition, there are Music, Dance, Dramatics, Arturo, Fine Arts, Literary, Music clubs and also Science & Technology, Robotic Societies, Monochrome, Computer Integrated Manufacturing, Astronomy, Quiz, Coding clubs where the students can participate and develop a well– rounded personality.

12 Recreational Facilities

At present, the transit campus has excellent facilities for several sports, including a cricket field, three lawn tennis courts, a football field, a hockey field, a gymnasium, a basket ball court, badminton courts, an athletics track, table tennis room and also facilities for several athletic events. The institute encourages its students to participate in inter-IIT sport events and other competitions. Space for recreational and creative activities is also available. The institute is actively involved in collaboration programs with international organizations and universities. The institute has the following facilities other than the basic academic facilities. Virtual Classrooms (NKN) Two virtual classrooms have been set up at IIT Ropar. NKN interconnect the institutions engaged in research, higher education and scientific development in the country.

13 General Facilities

The Institute has a branch of SBI as well as a Post office to cater to the needs of the faculty members, staff and students.

14 Details of Medals

Name of the Medal	Criteria for Award
President of India Gold Medal	To a candidate who obtains the highest CGPA among all students obtaining a B.Tech. degree in that year from the 4 year B.Tech. programme. In case there is a tie, the medal is awarded to the student with the largest earned credits.
Director Gold Medal	To a candidate who is adjudged as the best all- rounder from amongst the graduating students of the 4 year B.Tech. programme.
Institute Gold Medal	To a candidate securing a CGPA of 10, other than the one who has been awarded the President of India Gold medal.
Institute Silver Medal (For each programme)	To a candidate (one in each programme) who obtains the highest CGPA among and undergraduate graduating class of the Institute in his/her programme. No silver medal will be awarded in the discipline from which a student gets the President's Gold Medal & Institute Gold Medal. A minimum CGPA of 8.5 is required for the Institute Silver Medal; in case no graduating student satisfies this criterion, the student with the highest CGPA is given a certificate.

15 Academic Calendar for the 1st Semester of Academic Year 2018-19

Please visit - www.iitrpr.ac.in/academic-calendar-0

CONTACT INFORMATION

Director	Prof. Sarit K. Das Tel. +91-1881-223391, 242101 Email: director@iitrpr.ac.in
Dean (Academics)	Prof. P. K. Raina Tel. +91-1881-227083, 242114 Email: deanar@iitrpr.ac.in
Dean (Faculty Affairs)	Prof. Deepak Kashyap Tel. +91-1881-242248 Email: deanfaa@iitrpr.ac.in
Dean (Research)	Prof. Javed Agrewala Tel. +91-1881-242311 Email: deanresearch@iitrpr.ac.in
Dean (Industrial Consultancy, Sponsored Research & Industry Interaction)	Prof. Harpreet Singh Tel. +91-1881-242313 Email: deanspc@iitrpr.ac.in
Dean (Transition Planning and Coordination)	Prof. Javagal K Sridhar Tel. +91-1881-242241 Email: deantpac@iitrpr.ac.in
Associate Dean (Academics-UG)	Dr. Anupam Agrawal Tel. +91-1881-242165 Email: deanug@iitrpr.ac.in
Associate Dean (Academics-PG)	Dr. Manoranjan Mishra Tel. +91-1881-242158 Email: deanpg@iitrpr.ac.in
Associate Dean (Student Affairs)	Dr. C C Reddy Tel. +91-1881-242192 Email: deansa@iitrpr.ac.in
Associate Dean (Continuing Education & Outreach Activities)	Dr. Asoka Biswas Tel. +91-1881-242141 Email: abiswas@iitrpr.ac.in
Associate Dean (International Relations)	Dr. Rohit Y Sharma Tel. +91-1881-242304 Email: deanir@iitrpr.ac.in
Associate Dean (Sponsored Research)	Dr. Arvind Kumar Gupta Tel. +91-1881-242140 Email: ak Gupta@iitrpr.ac.in
Officiating Registrar	Sh. Ravinder Kumar Email: registrar@iitrpr.ac.in
Deputy Registrar (Academics)	Sh. C.S. Sham Sundar Tel. +91-1881-242186 Email: aracademics@iitrpr.ac.in



INDIAN INSTITUTE OF TECHNOLOGY ROPAR
Nangal Road, Rupnagar, Punjab - 140001, India
www.iitrpr.ac.in